

**Part Number: PTR43-00072**

**Kit Contents**

Item #	Quantity Req'd.	Description
1	1	Performance Air Filter
2	1	Warning Label
3		

**Hardware Bag Contents**

Item #	Quantity Req'd.	Description
1		
2		
3		

**Additional Items Required For Installation**

Item #	Quantity Req'd.	Description
1		
2		
3		

**Conflicts**

None
------

**Recommended Tools**

Personal & Vehicle Protection	Notes
Safety Glasses or Goggles	
Blankets	
Special Tools	Notes
Installation Tools	Notes
Special Chemicals	Notes
VDC Approved Cleaner	

**General Applicability**

Corolla - 1.8L I4 → 2009-
Yaris - 1.8L I4 → 2006-2015
Matrix - 1.8L I4 → 2009-2013
Scion xD - 1.8L I4 → 2008-2015

**Recommended Sequence of Application**

Item #	Accessory
1	
2	
3	

\*Mandatory

**Vehicle Service Parts** (may be required for reassembly)

Item #	Quantity Req'd.	Description
1		
2		
3		

**Legend**



**STOP:** Damage to the vehicle may occur. Do not proceed until process has been complied with.



**OPERATOR SAFETY:** Use caution to avoid risk of injury.



**CAUTION:** A process that must be carefully observed in order to reduce the risk of damage to the accessory/vehicle and to ensure a quality installation.



**TOOLS & EQUIPMENT:** Used in Figures calls out the specific tools and equipment recommended for this process.



**REVISION MARK:** This mark highlights a change in installation with respect to previous issue.



**SAFETY TORQUE:** This mark indicates that torque is related to safety.



**TOYOTA**                      **YARIS**                      **2006 -**  
**COROLLA/MATRIX**                      **2009 -**  
**SCION**                      **XD**                      **2008 - 2015**  
Procedure

---

**TRD**  
**PERFORMANCE**  
**AIR FILTER**

Care must be taken when installing this accessory to ensure damage does not occur to the vehicle. The installation of this accessory should follow approved guidelines to ensure a quality installation.

These guidelines can be found in the "Accessory Installation Practices" document.

This document covers such items as:-

- Vehicle Protection (use of covers and blankets, cleaning chemicals, etc.).
- Safety (eye protection, rechecking torque procedure, etc.).
- Vehicle Disassembly/Reassembly (panel removal, part storage, etc.).
- Electrical Component Disassembly/Reassembly (battery disconnection, connector removal, etc.).

Please see your Toyota or Scion dealer for a copy of this document.

**1. Check the Contents and Prepare the Vehicle.**

(a) Check the box for contents and/or damage.



(b) Use blankets to protect the front grille and driver-side front fender area.

**2. Remove the OE Air Filter (2008 Scion xD shown).**

- (a) Unlatch the two air filter housing clips (Fig. 2-1 through Fig. 2-3).
- (b) Disengage the air cleaner tabs and lift the air filter housing lid up to expose the factory air filter.
- (c) Remove the factory air filter from the air filter housing and discard the filter.

Scion xD

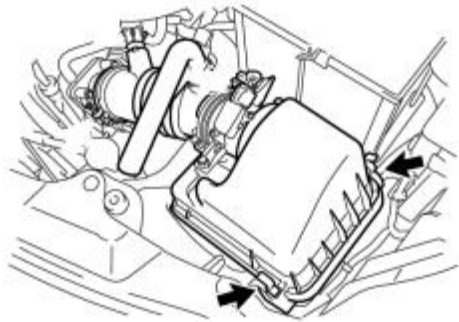

Fig. 2-1

Yaris

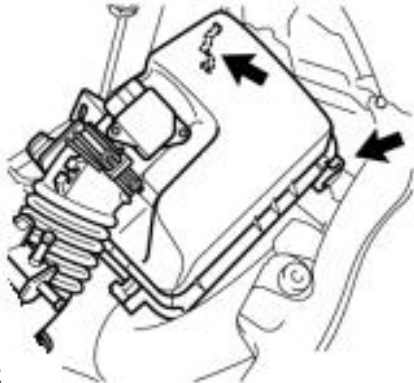

Fig. 2-2

Corolla/Matrix

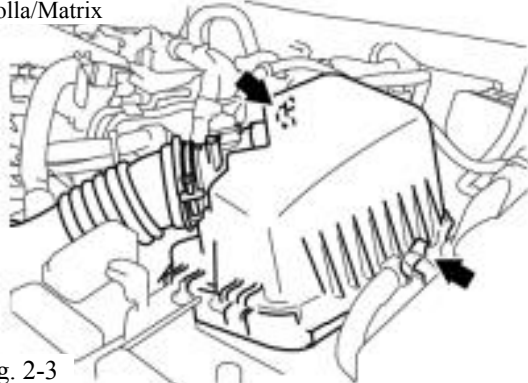
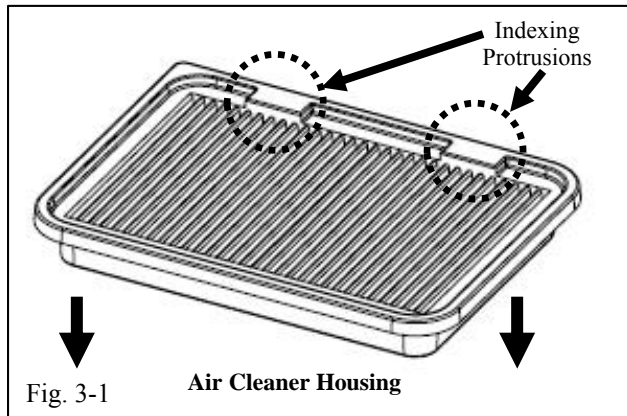

Fig. 2-3



**3. Install the TRD Air Filter (2008 Scion xD shown).**

- (a) Insert the TRD air filter into the air filter housing with the deep side of the filter down in the housing (Fig. 3-1).
- (b) Position the filter so that the indexing protrusions on the top of the filter align with the reliefs in the air cleaner lid (Fig. 3-1).
- (c) Move the air filter housing lid into place.
- (d) Re-latch the two air filter housing clips (Refer to Fig. 2-1 through Fig. 2-3).
- (e) Use a lint free cloth and an approved cleaner such as 3M Prep Solvent 70 or similar to clean the air filter housing lid.
- (f) Use a lint free cloth and water to clean the same area as in Step 3(e).

Procedure

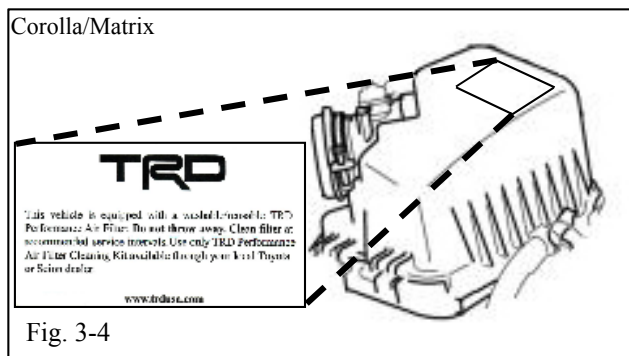
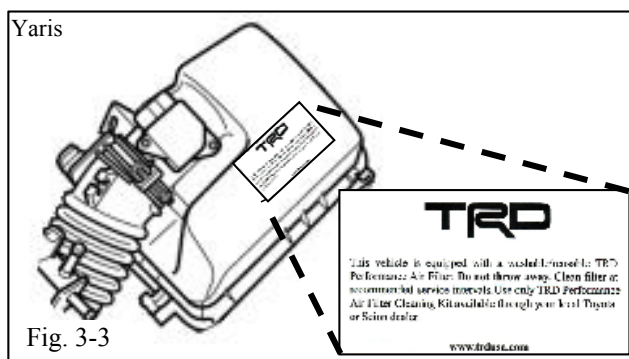
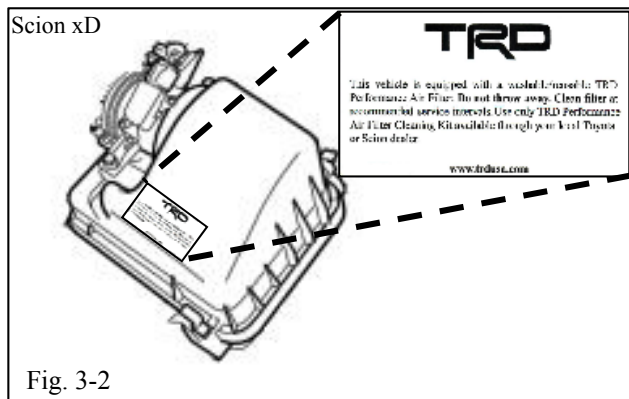

(g) Apply the TRD air filter warning label to the area pre-cleaned in Steps 3(e) and 3(f) (Fig. 3-2 through 3-4).

(h) Remove the blankets from the front fender and grille area.

TOYOTA YARIS 2006 -  
COROLLA/MATRIX 2009 -  
SCION XD 2008 - 2015

**TRD**  
**PERFORMANCE**  
**AIR FILTER**

Checklist - these points **MUST** be checked to ensure a quality installation.

<u>Check:</u>	<u>Look For:</u>
<p><u>Accessory Function Checks</u></p> <p><input type="checkbox"/> Air filter housing lid</p> <p><input type="checkbox"/></p> <p><input type="checkbox"/></p> <p><input type="checkbox"/></p>	<p>Reusable air filter warning label</p> <p>Air leaks/gaps</p>
<p><u>Vehicle Function Checks</u></p> <p><input type="checkbox"/></p> <p><input type="checkbox"/></p> <p><input type="checkbox"/></p>	
<p><u>Vehicle Appearance Check</u></p> <p><input type="checkbox"/> After accessory installation and removal of protective cover(s), perform a visual inspection.</p>	<p>Ensure no damage (including scuffs and scratches) was caused during the installation process. (For PPO installations, refer to TMS Accessory Quality Shipping Standard.)</p>